

## FOR USE

ALL FIRE ALARM SYSTEMS



## DUCUMENTATION

## DATASHEET

### Description

High Power Motor Siren

Motor siren series are suitable for using in the field of police, factory, marketplace, school, recreation ground, and so on.

Type s-283 siren is high power siren.

**The voltage rang:** AC220V.

**Colour:** RED.

**Mounting method:** Screwing mounting.

## CHARACTER

Motor siren series: Unique and scientific design, perfect for operation,safety and reliably. Beautiful performance become decoration with inner car that show very honour. It is suitable to various types cars. Design and produced in accordance with GB standard. Character: Digital technology and single molectron make, performance steady and reliable. Additional functions of two sets switched of light control in the panel. Design perfectly. Function: aux, yelp, hi-lo, wail-1,wail-2, siren, horn, super-siren. Yelp relay. Tool. Build in LID display, sound amplifying.

## SPECIFICATION

Model	FPE.S-283
Volt	220-240VAC
Ampair	1 A
Sound level	130-150dbx2
Size	115x145x165
RPM	5500

## Outline Drawing

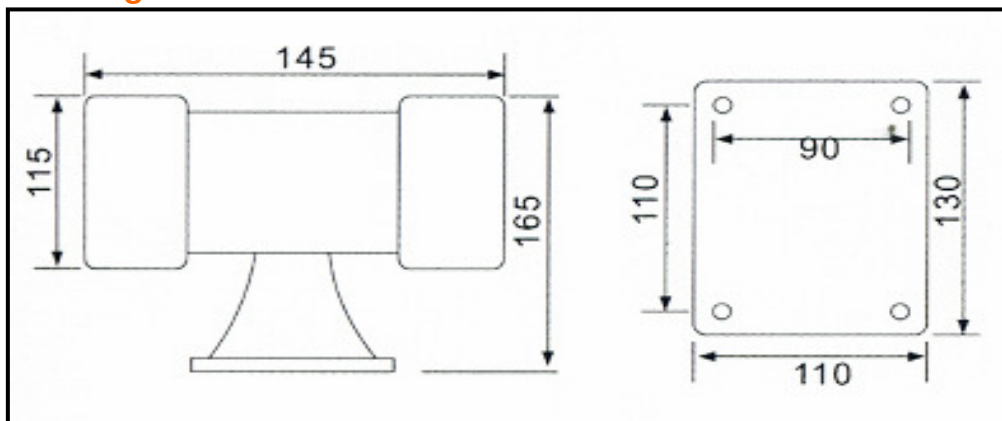

# FIRE PROTECTION EQUIPMENT CO.,LTD

357/32 Moo4 Klongsongtunnun,  
Ladkrabang, Bangkok 10520

Tel:02-906-9141-3  
Fax:02-906-9144

E-mail: fpe11@hotmail.com  
www.fpethailand.com

UPDATE 5/2007