

MANUAL ALARM WITH RESET

CATALOGUE Model. **FPE.CL-202**

CERTIFICATE ISO 9001:2000/CE/CNS 12681

FOR USE

ALL FIRE ALARM SYSTEMS UL/NFPA

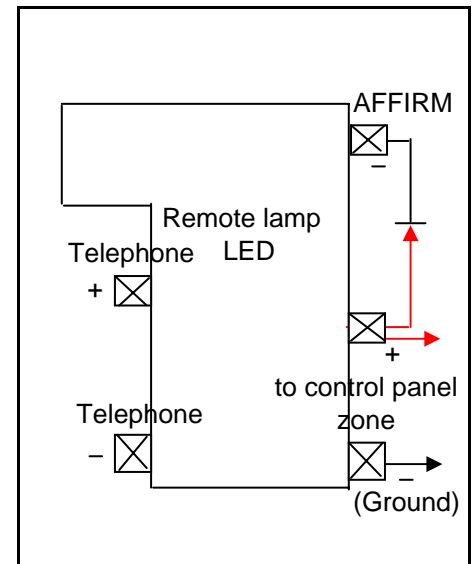

DUCUMENTATION

DATASHEET

This Fire Manual Station can quickly transmit a signal to the fire receiver terminals or the repeaters while the button under a transparent protective cover has been pushed at the first finding of a fire accident. (This signal is beyond the accumulated time limitation.)

There is a light over the button. The light will light up as a signal has been exactly received by the receiver terminal. There is also a telephone jack for telephone communication with attendant at the fire receiver terminal

FEATURE

- Reinforced transparent protective cover is reusable.
- All plastics are fire-proof, light, convenient and stylish.
- Auto-Return by pushing button, no need to disassemble the main body
- Outside cord distribution with terminators to ease on work.
- Response light available to identify the operation completed

SPECIFICATIONS

| | |
|---------------|---------------------|
| Model | FPE.CL-202 |
| Input voltage | 24VDC |
| Alarm current | DC, 100mA |
| Alarm confirm | red LED lamp |
| Size | 14 (dia.) x 4cm |
| Model | FPE.CL-205 |
| Boxbase | Size 14(dia) x 5 cm |



**Model.FPE.CL-205
MANUAL ALARM BASE**



FIRE PROTECTION EQUIPMENT CO.,LTD

357/32 Moo4 Klongsongtunnun, Ladkrabang, Bangkok 10520
Tel:02-906-9141-3 Fax:02-906-9144
E-mail:fpe11@hotmail.com www.fpethailand.com

UPDATE 5/2007